

# Metz mecablitz System SCA 300/3000: Welcher Adapter paßt zu Ihrer Kamera?

1. Zunächst die Gruppe Ihres Blitzgerätes laut den unten aufgeführten Abbildungen bestimmen.

- **Gruppe A und B:**  
SCA 300-Blitzgeräte
- **Gruppe C und D:**  
SCA 3000-Blitzgeräte
- **Gruppe E und F:**  
Sonderfall Nikon F3
- **Gruppe G und H:**  
Sonderfall Pentax LX
- **Gruppe I:**  
Sonderfall Mamiya/Bronica

2. In der Tabelle den entsprechenden Kameratyp suchen.

3. Dem jeweiligen Kameratyp und der entsprechenden Blitzgerätegruppe ist der richtige SCA-Adapter mit den möglichen Blitzsonderfunktionen zugeordnet.

Sind mehrere Adapter aufgeführt, empfehlen wir Ihnen, die Kombination mit den meisten Blitzsonderfunktionen zu verwenden.

## Folgende Hinweise sind dabei zu beachten:

### ● vom Adapter durchgeführte Funktion

- 1) wird vom Kamerahersteller selbst vertrieben
- 2) nur ab Adapter-Ausführung M1
- 3) nur ab Adapter-Ausführung M2
- 4) nur ab Adapter-Ausführung M3
- 5) mit Minolta Steuergerät
- 6) mit Minolta Fuß FS 1200
- 7) soweit mit Blitzgerät möglich ● vorhanden

### ○ von der Kamera durchgeführte Funktion

- 8) nicht mit Pentax MZ... – Kameras
  - 9) nicht mit 32 Z-2
  - 10) nur für 60 CT 4
  - 11) nicht mit SCA 346/2 AF Ausführung M2 und M3
  - 12) nur ab Adapter-Ausführung M4
  - 13) nur ab Adapter-Ausführung M5
- ◆ Nur im TTL - flash mode

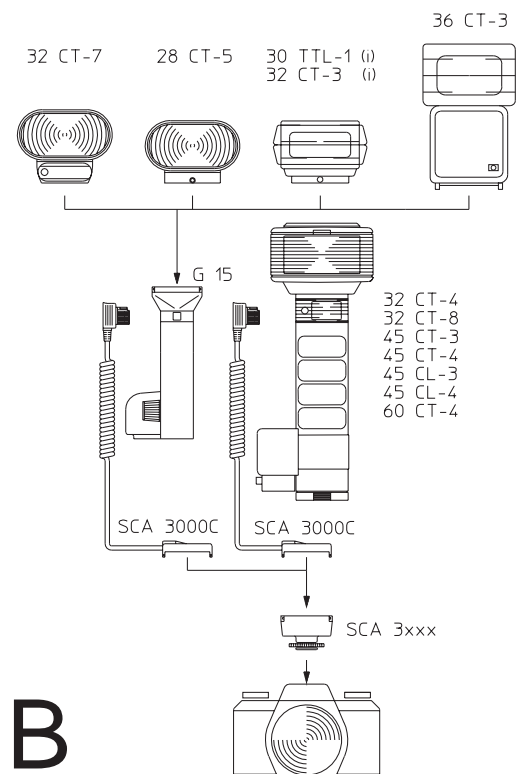
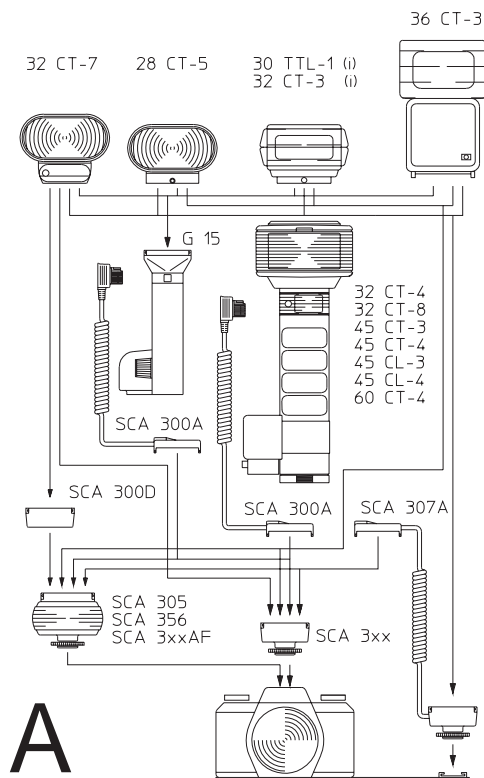

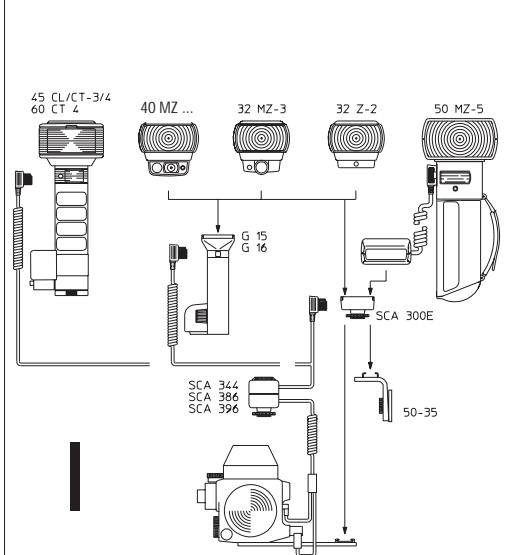
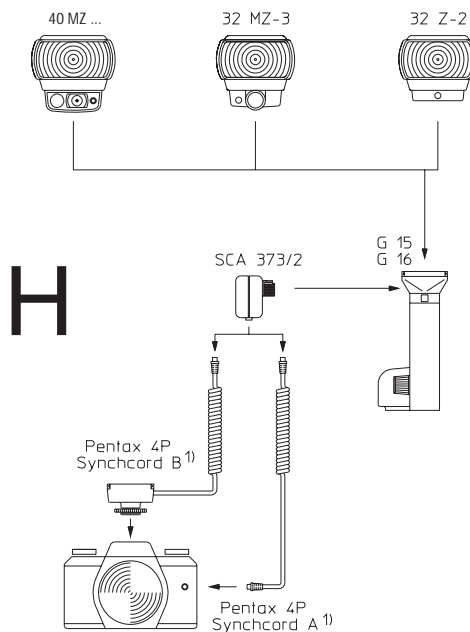
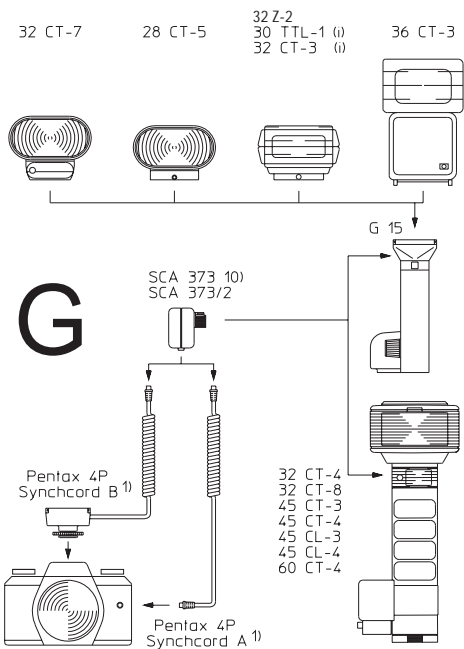
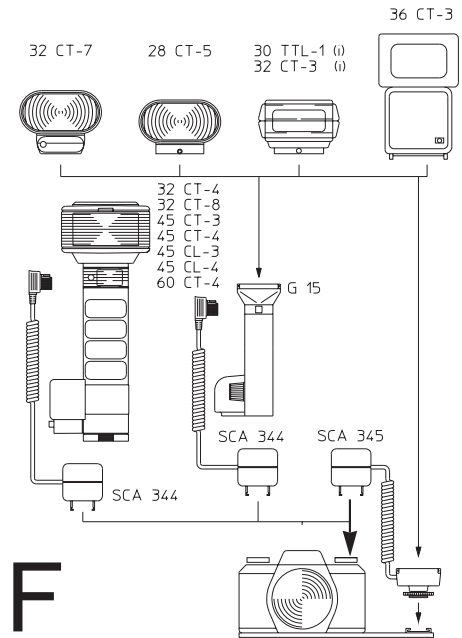
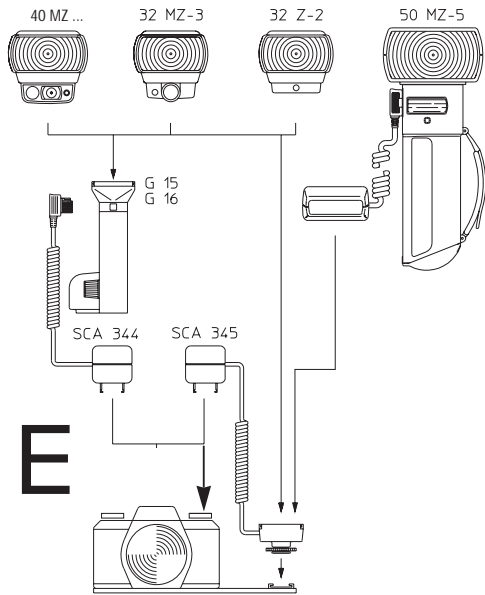
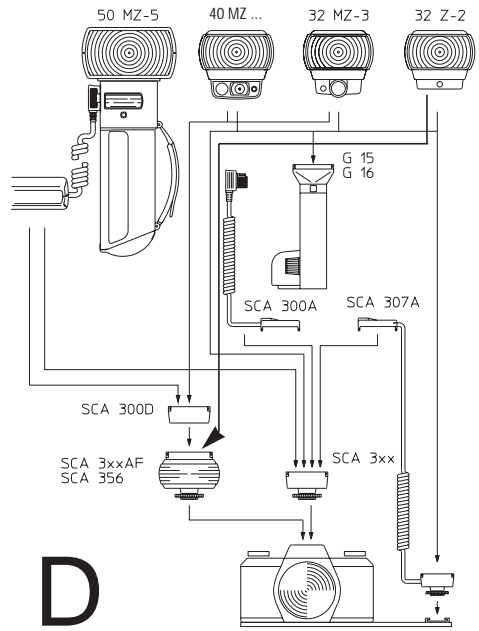
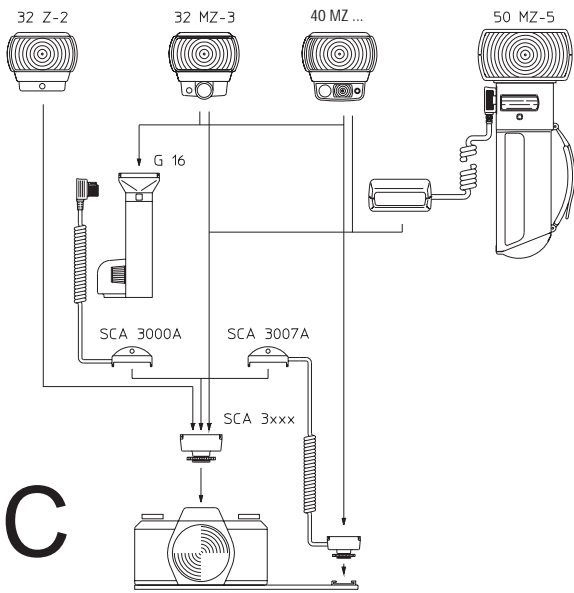







	Blitzgerät aus Gruppe	SCA-Adapter-Bezeichnung	Blitzbereitschafts-Anzeige im Kamera-Sucher	Belichtungs-kontroll-Anzeige im Kamera-Sucher	Automatische Blitzsynchron-zelsteuerung	TTL-Blitzsteuerung	TTL-Aufhell-Blitzsteuerung	TTL-Blitz-Belichtungs-Korrektur	A-TTL-Blitzsteuerung	Drahtlose TTL-Blitzsteuerung <sup>7)</sup>	Zündungssteuerung	Synchronisation 1. oder 2. Vorhang	Motorzoom-Steuerung <sup>7)</sup>	Autofocus-Meßblitzsteuerung <sup>7)</sup>	Blitzreichweiten-Anzeige <sup>7)</sup>	Programmblitz-Automatik	Automatische Blendensteuerung	Kontraststeuerung	3-D-Multisensor-Messung <sup>7)</sup>	Vorblitze gegen Rote Augen <sup>7)</sup>	Verbindungskabel SCA 3000 C, Anpassung von SCA 3000-Adaptoren an SCA 300-Stabblitz bzw. Kompaktblitz mit Powergriff G 15
<b>Pentax</b>																					
MV/MV-1	A D	372	●	●	●																
+Pentax 4P Synchcord B <sup>1)</sup>	G H	373, 373/2	●	●	●																
Progr. A/A3/A3000/P30/P30N/P3N/P30T/P50	A D	372	●	●	●																
+Pentax 4P Synchcord B <sup>1)</sup>	G H	373, 373/2	●	●	●																
Super A/645	A D	372	●	●	●	●					●										
+Pentax 4P Synchcord B <sup>1)</sup>	G H		●	●	●	●					●										
67 II (mit Handgriff)	A D	372	●	●	●	●										●					
SFX/SF1	A D	372	●		●	●					●										
	C	3701	●	●	●	●	●				●	●	●	●	●	●					
	B	3701	●	●	●	●	●				●	●	●	●	●	●					●
+Pentax 4P Synchcord B <sup>1)</sup>	G H	373, 373/2	●		●	●					●										
SFXn/SF1n/SF7/SF10	A D	372	●		●	●															
	C	3701	●	●	●	●	●				●	●	●	●	●	●					
	B	3701	●	●	●	●	●				●	●	●	●	●	●					●
+Pentax 4P Synchcord B <sup>1)</sup>	G H	373, 373/2	●		●	●				●											
MZ-10/Z-1/Z-10/Z-20/Z50P/ZX-5 PZ-1/PZ-10/PZ-20/MZ-5/MZ-5N (ab SCA 374/2AF-M2)/Z 70 (ab SCA 374/2AF M2/SCA3701 M1) MZ-50 / MZ-7	A D	374/2AF <sup>2)</sup>	●	●	●	●	●					●		●		●					
	C	3701	●	●	●	●	●					●	●	●	●	●					● <sup>8)</sup>
	B	3701	●	●	●	●	●					●	●	●	●	●					● <sup>8)</sup>
Z-1P/Z-5P	A D	374/2AF <sup>2)</sup>	●	●	●	●	●	●				●		●		●					
	C	3701	●	●	●	●	●	●				●	●	●	●	●					●
	B	3701	●	●	●	●	●	●				●	●	●	●	●					●
645 N	A D	372	●	●	●	●	●									●					
	C	3701	●	●	●	●	●				●	●	●	●	●	●					
	B	3701	●	●	●	●	●				●	●	●	●	●	●					●
<b>Praktica</b>																					
BMS	A D	321	●	●																	
BC 1/BCA	A D	321	●	●	●																
BX 20	A D	321	●	●	●	●															
<b>Ricoh</b>																					
XR-1S/KR-5S	A D	364	●																		
XR-2S/XR-S/XR-F/XR-7/ XR-6/XR-20SP/KR-10/ KR-10S/KR-30SP/KR-10M	A D	364	●		●																
XR-P/XR-X/XR-M	A D	364	●	●	●	●															
XR-X 3 PF	A D	364 <sup>2)</sup>	●	●	●	●	●	●													
<b>Rollei</b>																					
SL 2000F/3003/3001	A D	356 <sup>1)</sup>	●	●	●	●															
SL 66E/SL66X/SL66SE/2,8GX	A D	356 <sup>1)</sup>				●															
SL6006/SL6002/SL6008/SL6001	A D	356 <sup>1)</sup>	●	●		●															
<b>Sigma</b>																					
SA 300/SA 300 N	C	3601	●	●	●	●	●	●		●	●	●	●	●	●	●					●
	B	3601	●	●	●	●	●	●			●	●	●	●	●	●					●
<b>Yashica</b>																					
FX-D Quartz/107MP/108MP/109MP	A D	380 / 382	●		●																
FX-3 Super/FX-7 Super	A D	380 / 382	●																		
FX-103	A D	380 / 382	●	●	●	●															
200 AF	A D	380 / 382	●		●																
	A D	381 / 2AF	●		●								●								
230 AF	A D	380 / 382	●	●	●	●															
	A D	381 / 2AF	●	●	●	●								●							
270 AF/300 AF	A D	380 / 382	●		●									○							
	A D	381 / 2AF	●		●									○							